

8 7 6 5 4 3 2 1

REVISIONS				
ZONE	REV	DESCRIPTION	DATE	APPROVED

BOM	
1	STAND CAST IRON
2	CAP CAST IRON
3	LIFTING SCREW MACHINE STEEL F A O
4	SPECIAL SCREW MACHINE STEEL
5	LEVER COLD ROLLED STEEL

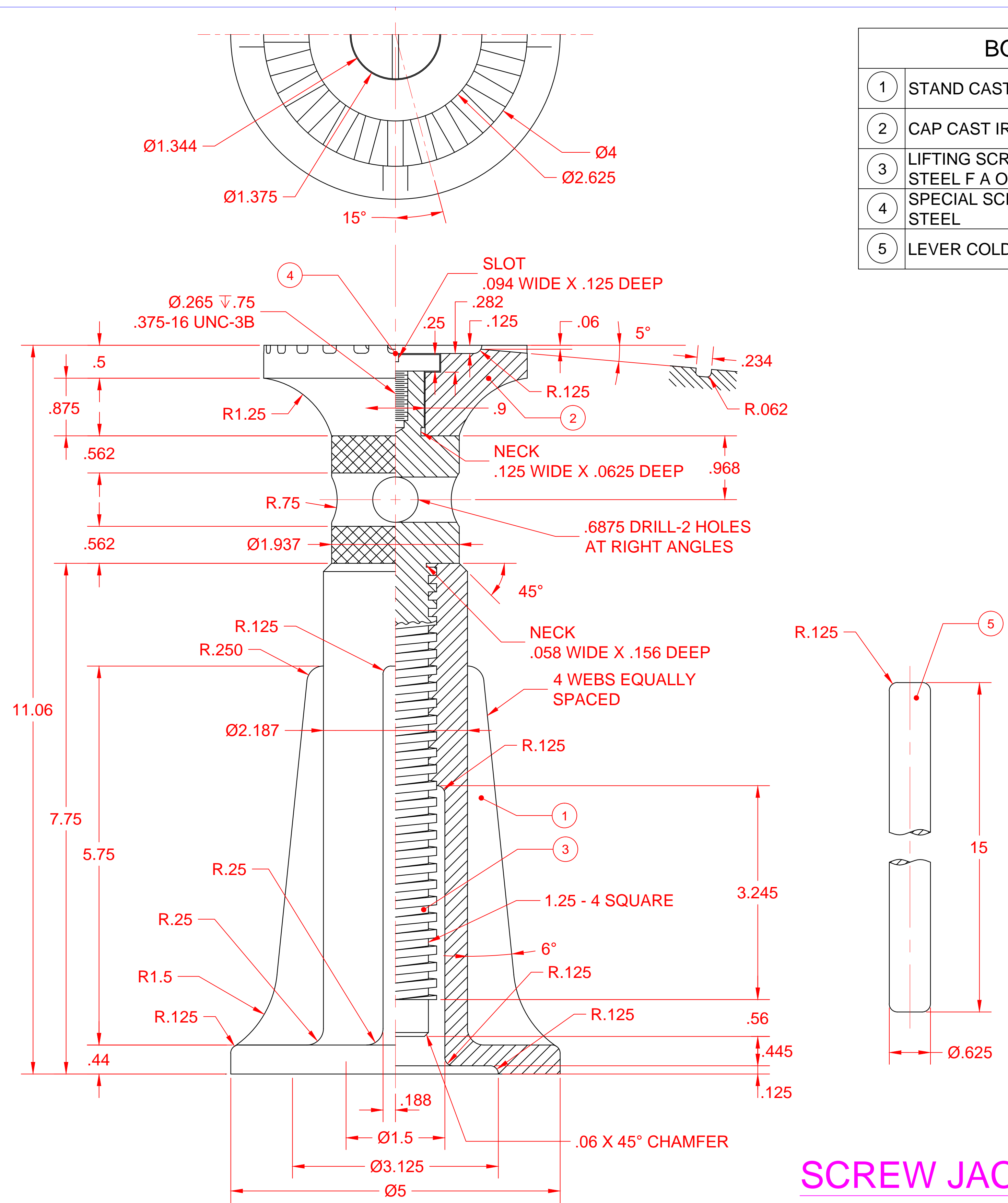

SCREW JACK

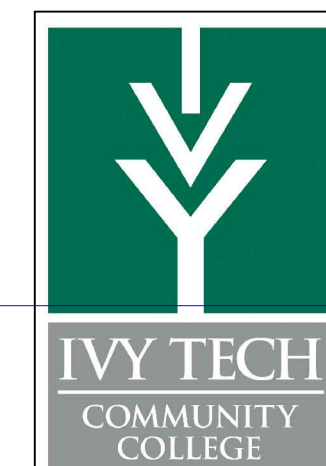

THIS MATERIAL IS PROPRIETARY AND IS NOT TO BE USED BY THE RECIPIENT FOR ANY PURPOSE OTHER THAN STATED BY THE OWNER OR CREATOR. THIS MATERIAL MAY NOT BE REPRODUCED OR DISCLOSED TO THIRD PARTIES WITHOUT CONSENT.

DESN113 - INTERMEDIATE CAD

SCREW JACK

TOLERANCES UNLESS OTHERWISE SPECIFIED:
 .XX= ±.005 FRACTIONS ± 1/32
 .XXX= ±.0005 ANGLES ± 1°

SIZE	MATERIAL	DWG NO.	REV
D	STEEL	DESN113-20C-mmartin	
SCALE	1:1	MARI MARTIN	SHEET 1/1

8 7 6 5 4 3 2 1

PRODUCED BY AN AUTODESK EDUCATIONAL PRODUCT

PRODUCED BY AN AUTODESK EDUCATIONAL PRODUCT