

| | | |
|---------------------------|----------------|-----------|
| Title: 15b | | |
| 15b | | |
| Designed by: Juddo Abaker | Document N: | Revision: |
| Checked by: | Date: 5/4/2018 | Size: A |
| Approved by: | Sheet 1 of 1 | |

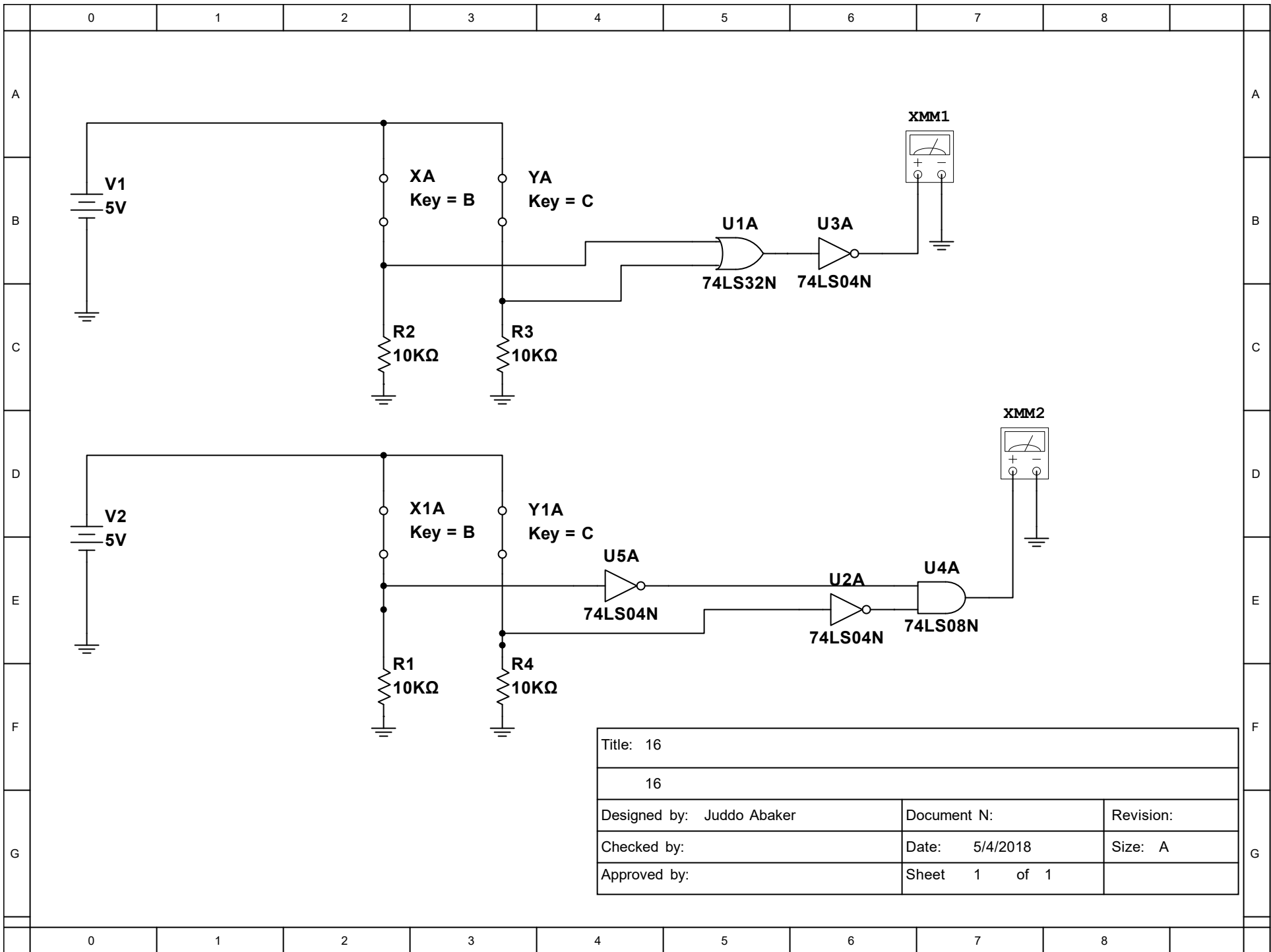

| | | |
|---------------------------|----------------|-----------|
| Title: 16 | | |
| 16 | | |
| Designed by: Juddo Abaker | Document N: | Revision: |
| Checked by: | Date: 5/4/2018 | Size: A |
| Approved by: | Sheet 1 of 1 | |

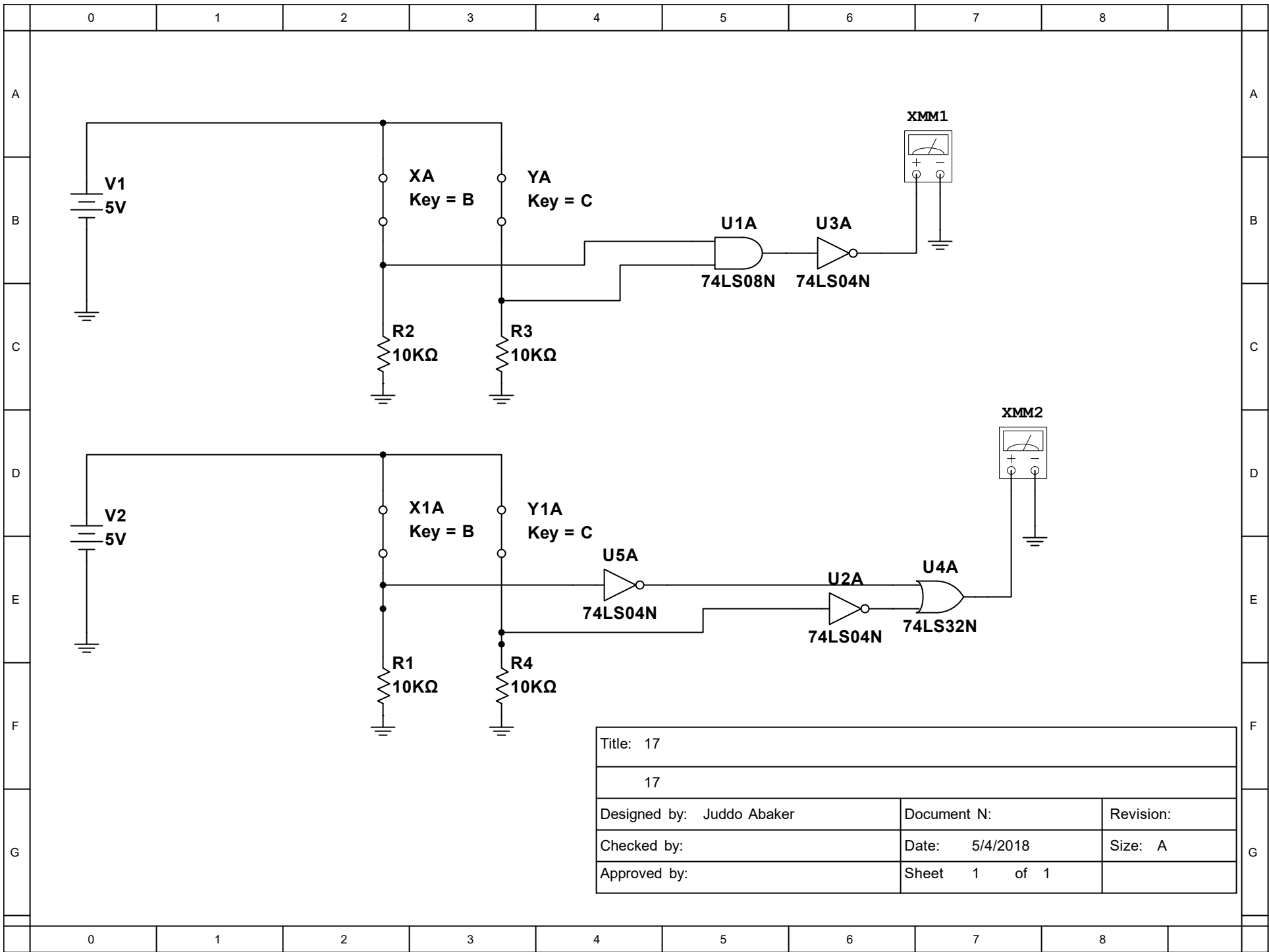

| | | |
|---------------------------|----------------|-----------|
| Title: 17 | | |
| 17 | | |
| Designed by: Juddo Abaker | Document N: | Revision: |
| Checked by: | Date: 5/4/2018 | Size: A |
| Approved by: | Sheet 1 of 1 | |

1 $x \cdot 0 = 0$

| X | Sim | Lab | |
|---|-----|-------|---------|
| | | Logic | Volts |
| 0 | 0 | 0 | 0.1348V |
| 1 | 0 | 0 | 0.1351V |

2 $x \cdot 1 = x$

| X | Sim | Lab | |
|---|-----|-------|---------|
| | | Logic | Volts |
| 0 | 0 | 0 | 0.1365V |
| 1 | 1 | 1 | 4.1150V |

3 $x \cdot x = x$

| X | Sim | Lab | |
|---|-----|-------|---------|
| | | Logic | Volts |
| 0 | 0 | 0 | 0.1339V |
| 1 | 1 | 1 | 4.1071V |

4 $x \cdot \bar{x} = 0$

| X | Sim | Lab | |
|---|-----|-------|--------|
| | | Logic | Volts |
| 0 | 0 | 0 | 0.1348 |
| 1 | 0 | 0 | 0.1349 |

5 $x + 0 = x$

| X | Sim | Lab | |
|---|-----|-------|---------|
| | | Logic | Volts |
| 0 | 0 | 0 | 0.1612V |
| 1 | 1 | 1 | 4.4188V |

6 $x + 1 = 1$

| X | Sim | Lab | |
|---|-----|-------|---------|
| | | Logic | Volts |
| 0 | 1 | 1 | 4.4226V |
| 1 | 1 | 1 | 4.4181V |

7 $x \cdot x = x$

| X | Sim | Lab | |
|---|-----|-------|---------|
| | | Logic | Volts |
| 0 | 0 | 0 | 0.1619v |
| 1 | 1 | 1 | 4.4202V |

8 $x + \bar{x} = 1$

| X | Sim | Lab | |
|---|-----|-------|---------|
| | | Logic | Volts |
| 0 | 1 | 1 | 4.4260V |
| 1 | 1 | 1 | 4.4254V |

13A $x \cdot (y + z) = xy + xz$

| X | Y | Z | Simulation | | Lab | | | |
|---|---|---|------------|-------------|------------|-------------|------------|-------------|
| | | | Left Logic | Right Logic | Left Logic | Right Logic | Left Volts | Right Volts |
| 0 | 0 | 0 | 0 | 0 | 0 | 0 | 0.1345V | 0.1640V |
| 0 | 0 | 1 | 0 | 0 | 0 | 0 | 0.1352V | 0.1638V |
| 0 | 1 | 0 | 0 | 0 | 0 | 0 | 0.1352V | 0.1638V |
| 0 | 1 | 1 | 0 | 0 | 0 | 0 | 0.1355V | 0.1640V |
| 1 | 0 | 0 | 0 | 0 | 0 | 0 | 0.1348v | 0.1642V |
| 1 | 0 | 1 | 1 | 1 | 1 | 1 | 4.0719V | 4.3879V |
| 1 | 1 | 0 | 1 | 1 | 1 | 1 | 4.0718V | 4.3865V |
| 1 | 1 | 1 | 1 | 1 | 1 | 1 | 4.0706V | 4.3852V |

13B $(w + x) \cdot (y + z) = wy + xy + wz + xz$

| W | X | Y | Z | Simulation | | Lab | | | |
|---|---|---|---|------------|-------------|------------|-------------|------------|-------------|
| | | | | Left Logic | Right Logic | Left Logic | Right Logic | Left Volts | Right Volts |
| 0 | 0 | 0 | 0 | 0 | 0 | 0 | 0 | 0.1185V | 0.1595V |
| 0 | 0 | 0 | 1 | 0 | 0 | 0 | 0 | 0.1188V | 0.1594V |
| 0 | 0 | 1 | 0 | 0 | 0 | 0 | 0 | 0.1189V | 0.1594V |
| 0 | 0 | 1 | 1 | 0 | 0 | 0 | 0 | 0.1192V | 0.1595V |
| 0 | 1 | 0 | 0 | 0 | 0 | 0 | 0 | 0.1196V | 0.1594V |
| 0 | 1 | 0 | 1 | 1 | 1 | 1 | 1 | 4.1694V | 4.4237V |
| 0 | 1 | 1 | 0 | 1 | 1 | 1 | 1 | 4.1680V | 4.4227V |
| 0 | 1 | 1 | 1 | 1 | 1 | 1 | 1 | 4.1667V | 4.4213V |
| 1 | 0 | 0 | 0 | 0 | 0 | 0 | 0 | 0.1201V | 0.1595V |
| 1 | 0 | 0 | 1 | 1 | 1 | 1 | 1 | 4.1660V | 4.4233V |
| 1 | 0 | 1 | 0 | 1 | 1 | 1 | 1 | 4.1654V | 4.4227V |
| 1 | 0 | 1 | 1 | 1 | 1 | 1 | 1 | 4.1645V | 4.4214V |
| 1 | 1 | 0 | 0 | 0 | 0 | 0 | 0 | 0.1204V | 0.1597V |
| 1 | 1 | 0 | 1 | 1 | 1 | 1 | 1 | 4.1646V | 4.4226V |
| 1 | 1 | 1 | 0 | 1 | 1 | 1 | 1 | 4.1642V | 4.4218V |
| 1 | 1 | 1 | 1 | 1 | 1 | 1 | 1 | 4.1641V | 4.4205V |

14 $x + xy = x$

| X | Y | Simulation | | Lab | | | |
|---|---|------------|-------------|------------|-------------|------------|-------------|
| | | Left Logic | Right Logic | Left Logic | Right Logic | Left Volts | Right Volts |
| 0 | 0 | 0 | 0 | 0 | 0 | 0.5671V | 0.1598V |
| 0 | 1 | 0 | 0 | 0 | 0 | 0.7452V | 0.1598V |
| 1 | 0 | 1 | 1 | 1 | 1 | 5.0352V | 4.4206V |
| 1 | 1 | 1 | 1 | 1 | 1 | 5.0039V | 4.4196V |

15A $x + \bar{x}y = x + y$

| X | Y | Simulation | | Lab | | | |
|---|---|------------|-------------|------------|-------------|------------|-------------|
| | | Left Logic | Right Logic | Left Logic | Right Logic | Left Volts | Right Volts |
| 0 | 0 | 0 | 0 | 0 | 0 | 0.1601V | 0.1646V |
| 0 | 1 | 1 | 1 | 1 | 1 | 4.4219V | 4.4187V |
| 1 | 0 | 1 | 1 | 1 | 1 | 4.4206V | 4.4197V |
| 1 | 1 | 1 | 1 | 1 | 1 | 4.4199V | 4.4167V |

15B $\bar{x} + xy = \bar{x} + y$

| X | Y | Simulation | | Lab | | | |
|---|---|------------|-------------|------------|-------------|------------|-------------|
| | | Left Logic | Right Logic | Left Logic | Right Logic | Left Volts | Right Volts |
| 0 | 0 | 1 | 1 | 1 | 1 | 4.4206V | 4.4211V |
| 0 | 1 | 1 | 1 | 1 | 1 | 4.4195V | 4.4207V |
| 1 | 0 | 0 | 0 | 0 | 0 | 0.1642V | 0.1635V |
| 1 | 1 | 1 | 1 | 1 | 1 | 4.4176V | 4.4171V |

16 $\overline{(x + y)} = \bar{x} \cdot \bar{y}$

| X | Y | Simulation | | Lab | | | |
|---|---|------------|-------------|------------|-------------|------------|-------------|
| | | Left Logic | Right Logic | Left Logic | Right Logic | Left Volts | Right Volts |
| 0 | 0 | 1 | 1 | 1 | 1 | 4.4473V | 4.1109V |
| 0 | 1 | 0 | 0 | 0 | 0 | 0.1112V | 0.1356V |
| 1 | 0 | 0 | 0 | 0 | 0 | 0.1112V | 0.1356V |
| 1 | 1 | 0 | 0 | 0 | 0 | 0.1114V | 0.1359V |

17 $\overline{(x \cdot y)} = \bar{x} + \bar{y}$

| X | Y | Simulation | | Lab | | | |
|---|---|------------|-------------|------------|-------------|------------|-------------|
| | | Left Logic | Right Logic | Left Logic | Right Logic | Left Volts | Right Volts |
| 0 | 0 | 1 | 1 | 1 | 1 | 4.4181V | 4.4416V |
| 0 | 1 | 1 | 1 | 1 | 1 | 4.4179V | 4.4396V |
| 1 | 0 | 1 | 1 | 1 | 1 | 4.4190V | 4.4328V |
| 1 | 1 | 0 | 0 | 0 | 0 | 0.1599V | 0.1120V |

13a sims

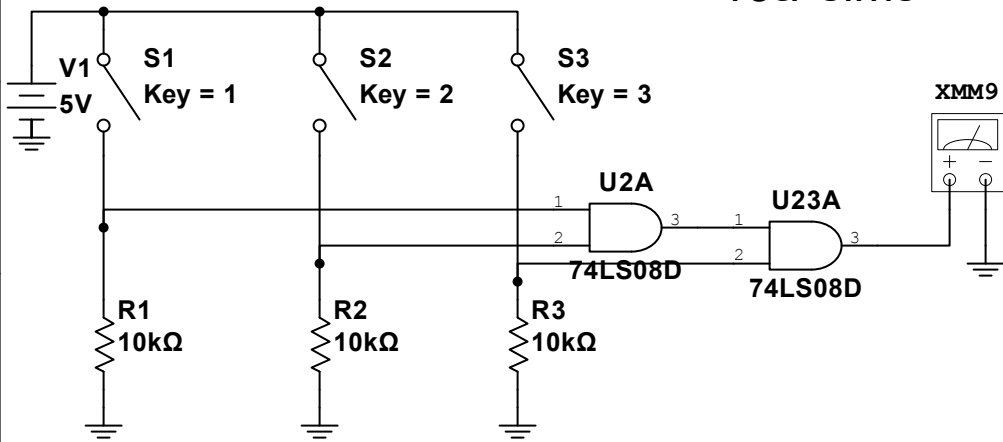

Theorem 13A first part of the equation part 74ls08
5volts DC is applied to pin 14 and ground applied to pin 7

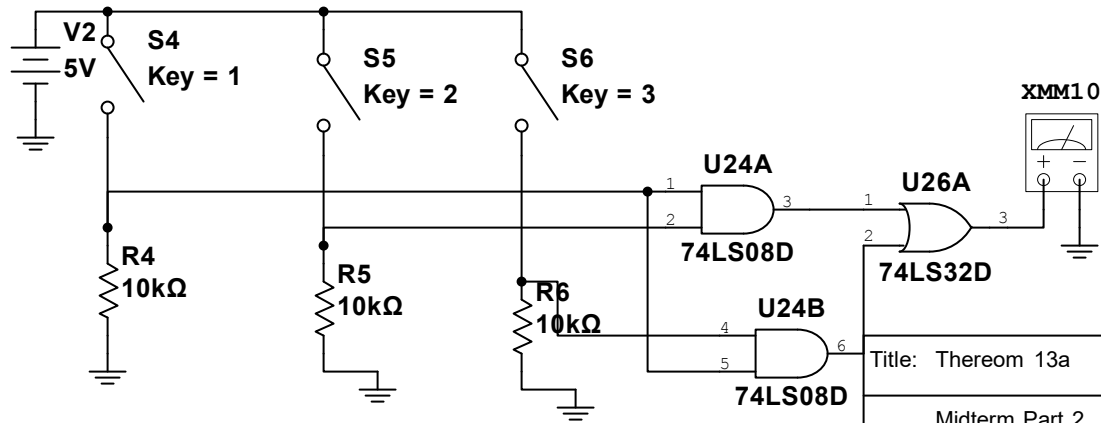

Theorem 13A second part of the equation part 74ls08 and 74ls32
5volts DC is applied to pin 14 and ground applied to pin 7

| | | |
|---------------------------|----------------|-----------|
| Title: Thereom 13a | | |
| Midterm Part 2 | | |
| Designed by: Juddo Abaker | Document N: | Revision: |
| Checked by: | Date: 5/4/2018 | Size: A |
| Approved by: | Sheet 1 of 1 | |

13b Sims

Theorem 13b first part 74ls32 and 74ls08. 5volts are applied to pin 14 and ground is applied to pin 7

Theorem 13b second part 74ls08 and 74ls32. 5 volts is applied to pin 14 and ground is pin 7

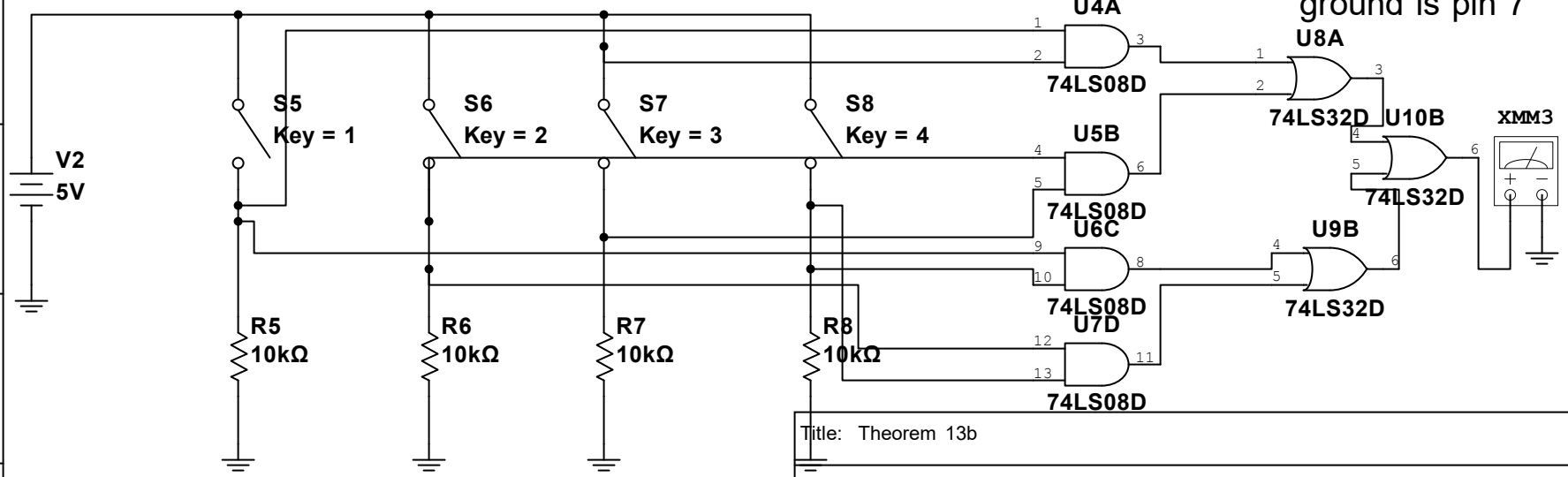
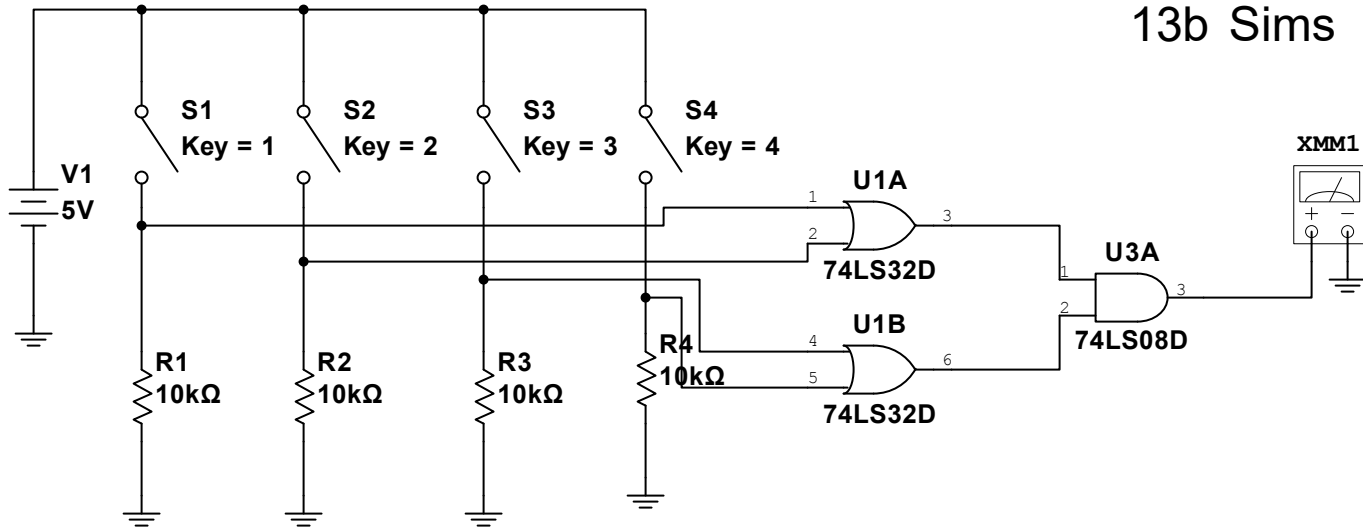

| | | |
|---------------------------|----------------|-----------|
| Title: Theorem 13b | | |
| Midterm Part 3 | | |
| Designed by: Juddo Abaker | Document N: | Revision: |
| Checked by: | Date: 5/4/2018 | Size: A |
| Approved by: | Sheet 1 of 1 | |

14 Sim

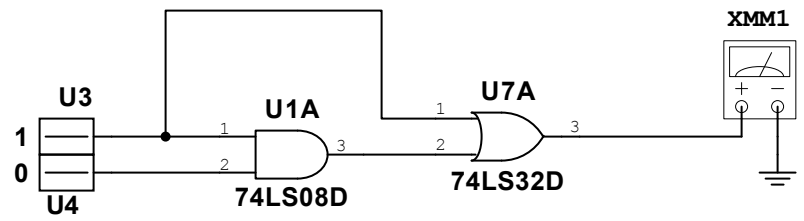

Theorem 14 parts 74ls08 and 74ls32 5 volts DC is applied to pin 14 and ground is applied to pin 7

15a sims

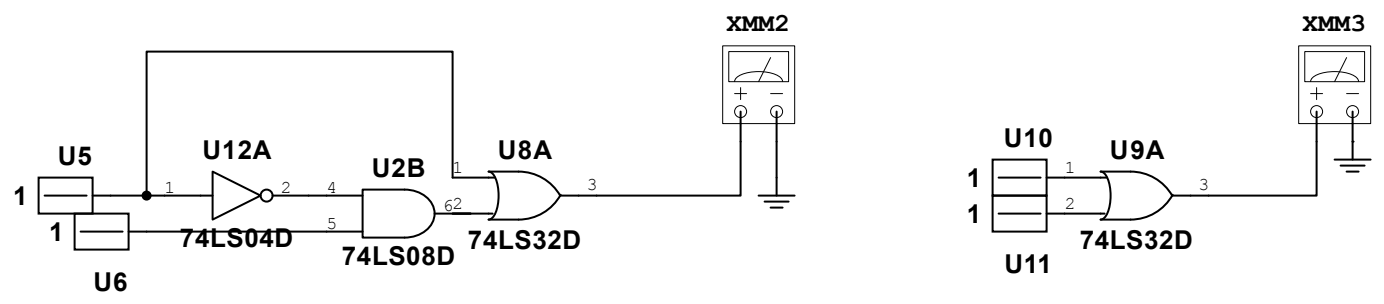

| | | |
|----------------------------|----------------|-----------|
| Title: Theorems 14 and 15a | | |
| Midterm Part 3 | | |
| Designed by: Juddo Abaker | Document N: | Revision: |
| Checked by: | Date: 5/4/2018 | Size: A |
| Approved by: | Sheet 1 of 1 | |

15b sims

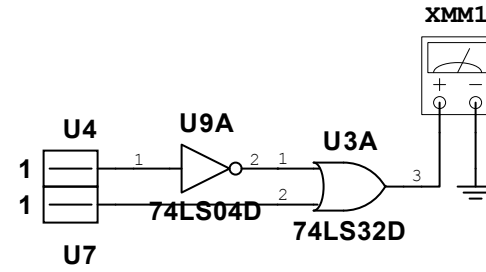
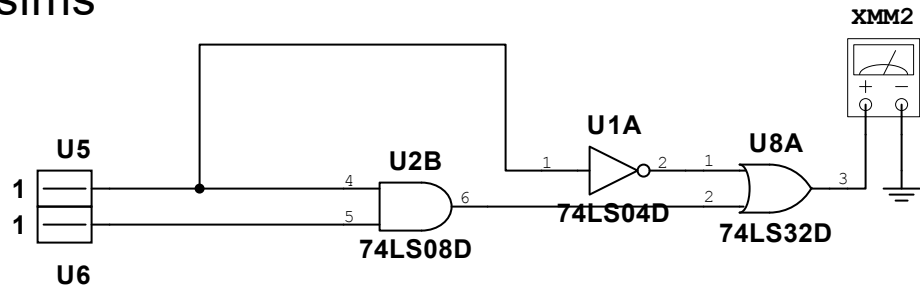

16 sims

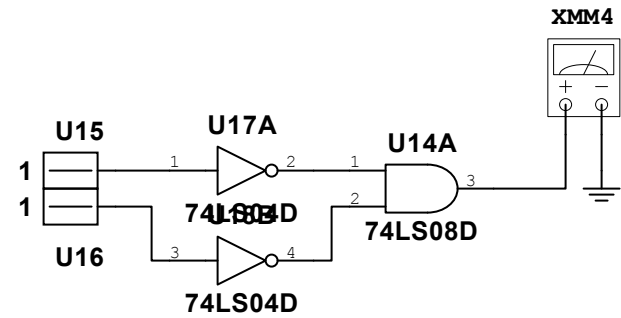
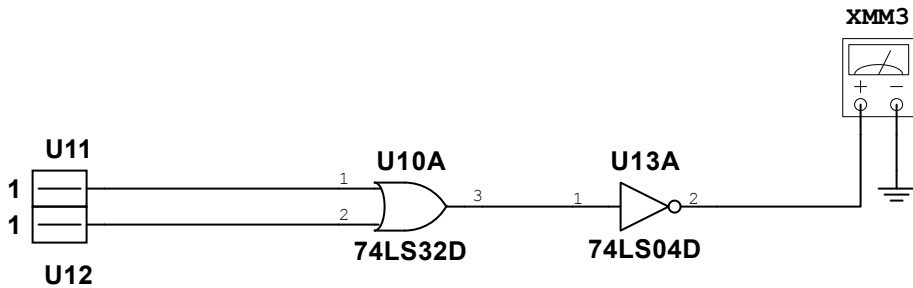

Title: Theorems 15b and 16

Midterm Part 5

Designed by: Juddo Abaker

Document N:

Revision:

Checked by:

Date: 5/4/2018

Size: A

Approved by:

Sheet 1 of 1

15b sims

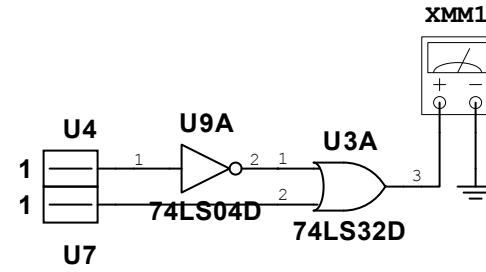
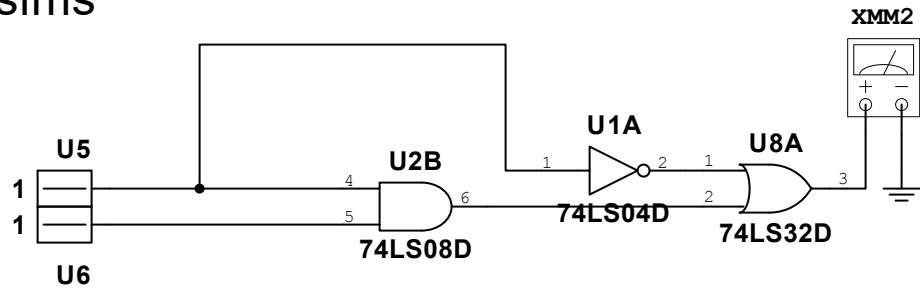

16 sims

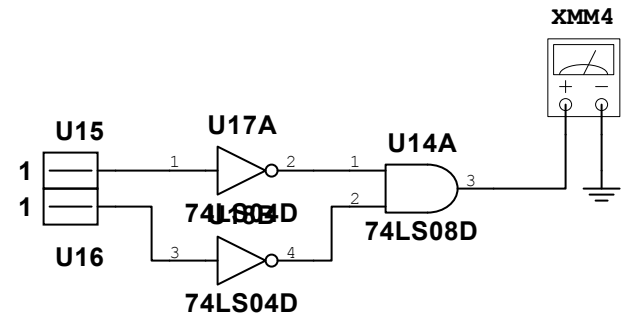
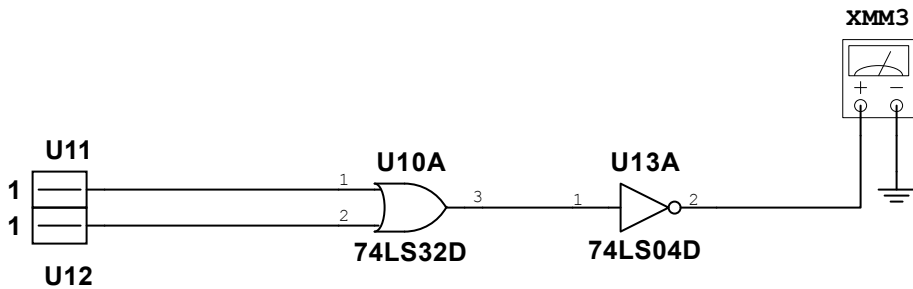

Title: Theorems 15b and 16

Midterm Part 5

Designed by: Juddo Abaker

Document N:

Revision:

Checked by:

Date: 5/4/2018

Size: A

Approved by:

Sheet 1 of 1

Theorems 1-4

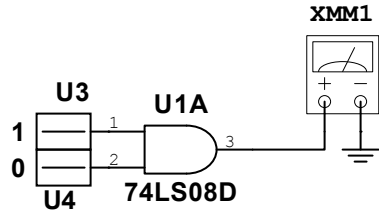

Theorem 1-3 Part 74ls08
5volts DC is applied to pin 14
ground is applied to pin 7

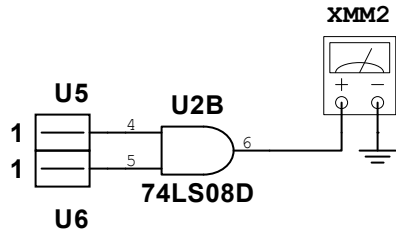

XMM2

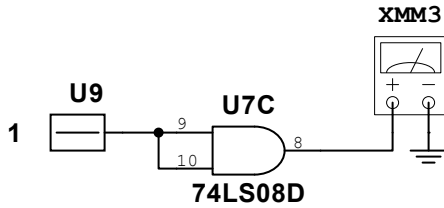

XMM3

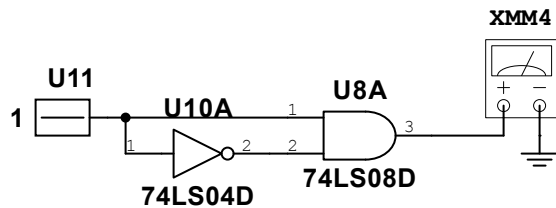

XMM4

Theorem 4 Part 74ls08
and 74ls04
5volts is applied to pin 14
and ground is applied to pin 7

Theorems 5-8

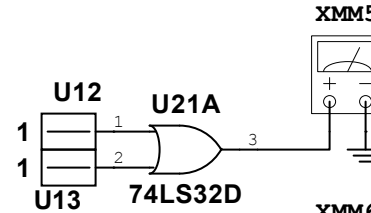

Theorem 5-7 Part 74ls32
5volts DC is applied to pin 14
ground is applied to pin 7

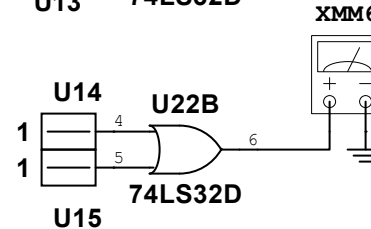

XMM6

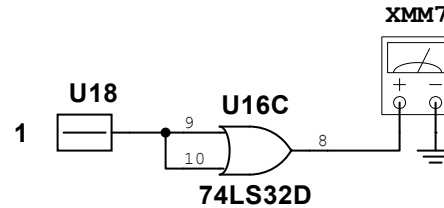

XMM7

Theorem 8 Part 74ls08 and
74ls04
5volts DC is applied to pin 14
ground is applied to pin 7

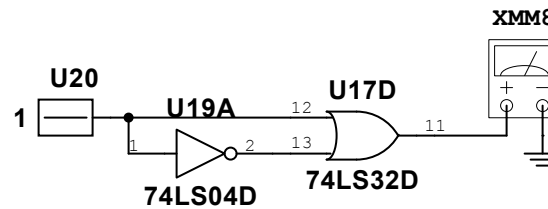

XMM8

| | | |
|---------------------------|----------------|-----------|
| Title: Theorems 1-8 | | |
| Midterm | | |
| Designed by: Juddo Abaker | Document N: | Revision: |
| Checked by: | Date: 5/4/2018 | Size: A |
| Approved by: | Sheet 1 of 1 | |

Theorems 1-4

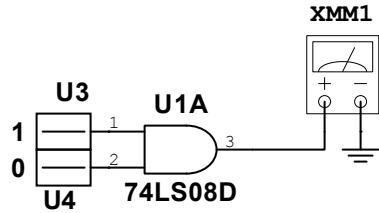

Theorem 1-3 Part 74ls08
5volts DC is applied to pin 14
ground is applied to pin 7

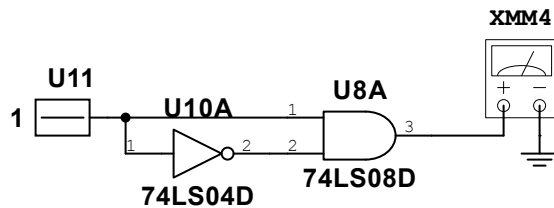
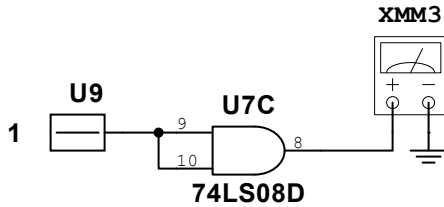
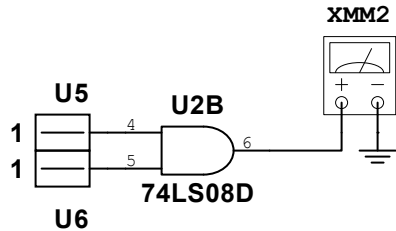

Theorem 4 Part 74ls08
and 74ls04
5volts is applied to pin 14
and ground is applied to pin 7

Theorems 5-8

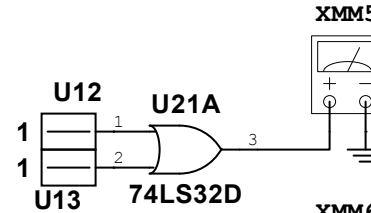

Theorem 5-7 Part 74ls32
5volts DC is applied to pin 14
ground is applied to pin 7

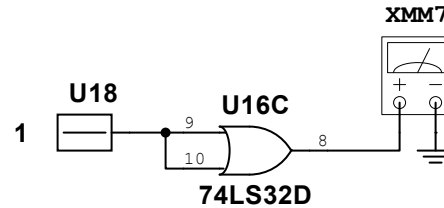
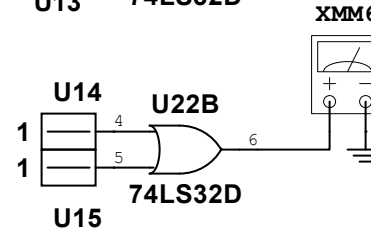

Theorem 8 Part 74ls08 and
74ls04
5volts DC is applied to pin 14
ground is applied to pin 7

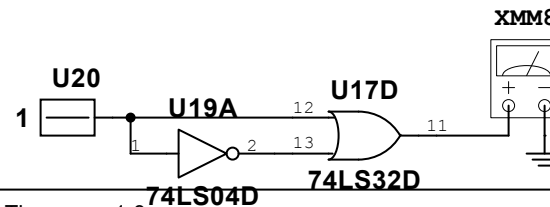

Title: Theorems 1-8

Midterm2

Designed by: Juddo Abaker

Document N:

Revision:

Checked by:

Date: 5/4/2018

Size: A

Approved by:

Sheet 1 of 1

| | | |
|---------------------------|----------------|-----------|
| Title: lacture4-4 | | |
| Lacture 4.5 | | |
| Designed by: Juddo Abaker | Document N: | Revision: |
| Checked by: | Date: 5/4/2018 | Size: A |
| Approved by: | Sheet 1 of 1 | |

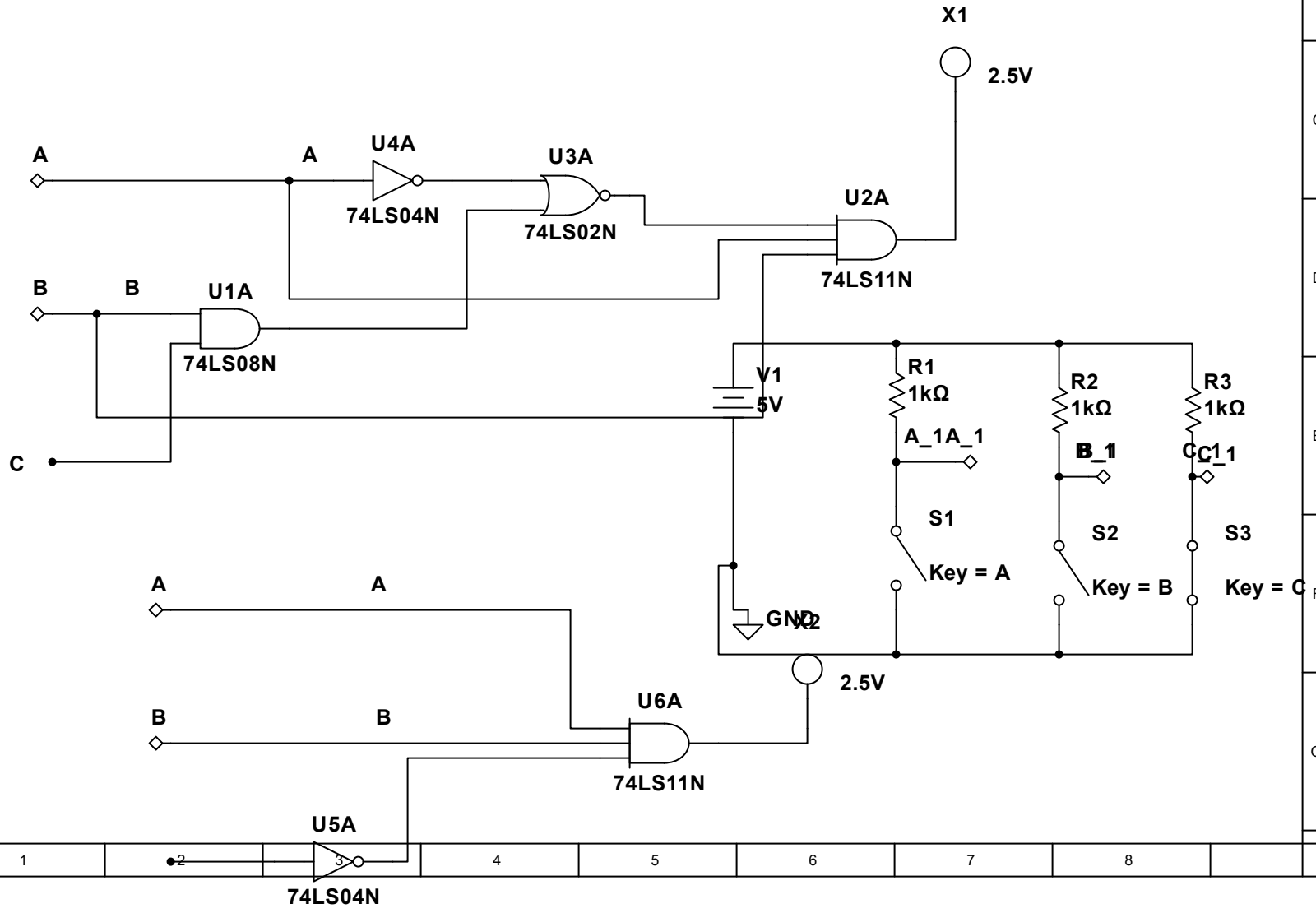

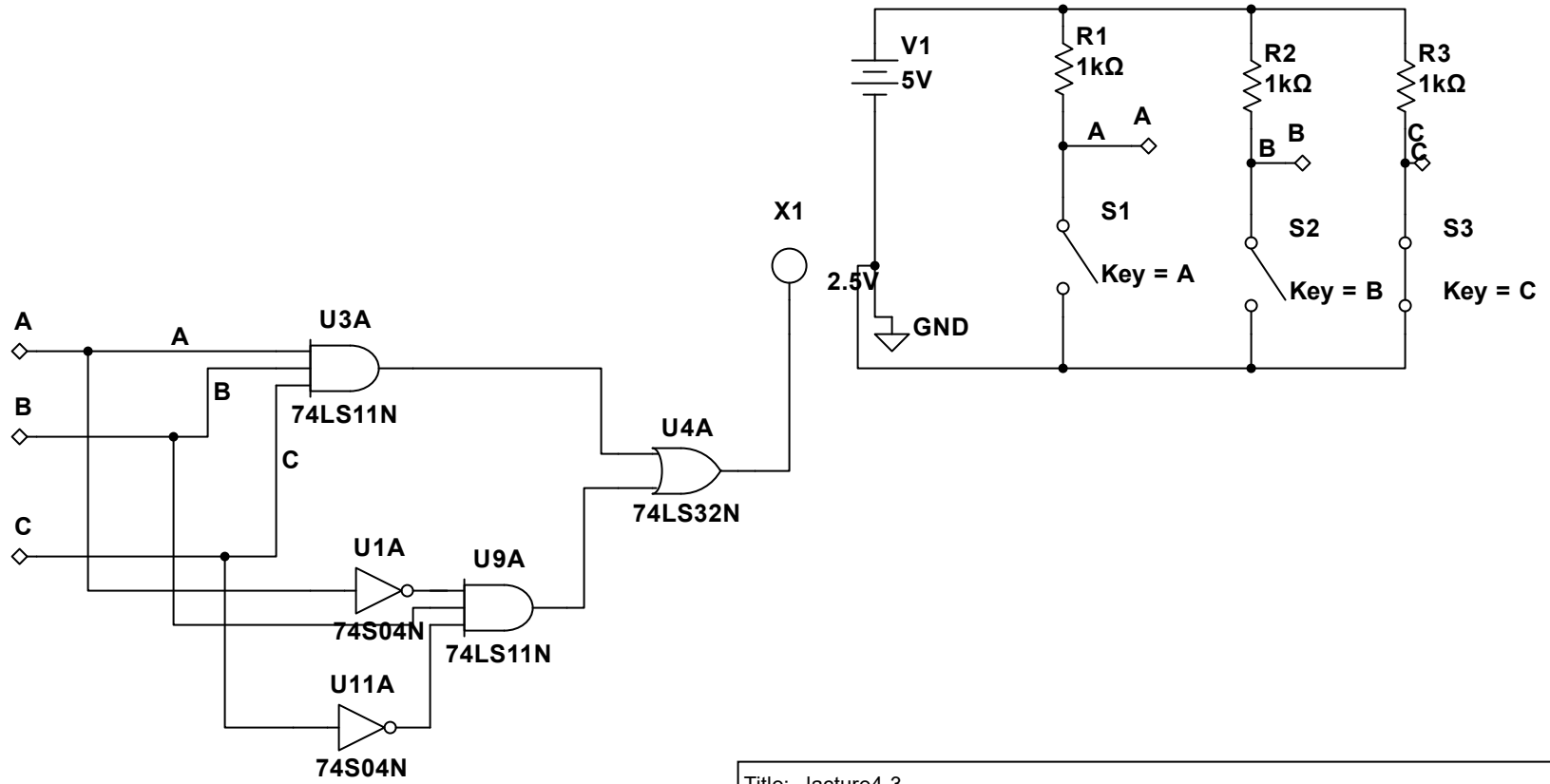

| | | |
|---------------------------|----------------|-----------|
| Title: lature4-3 | | |
| 4-3 | | |
| Designed by: Juddo Abaker | Document N: | Revision: |
| Checked by: | Date: 5/4/2018 | Size: A |
| Approved by: | Sheet 1 of 1 | |

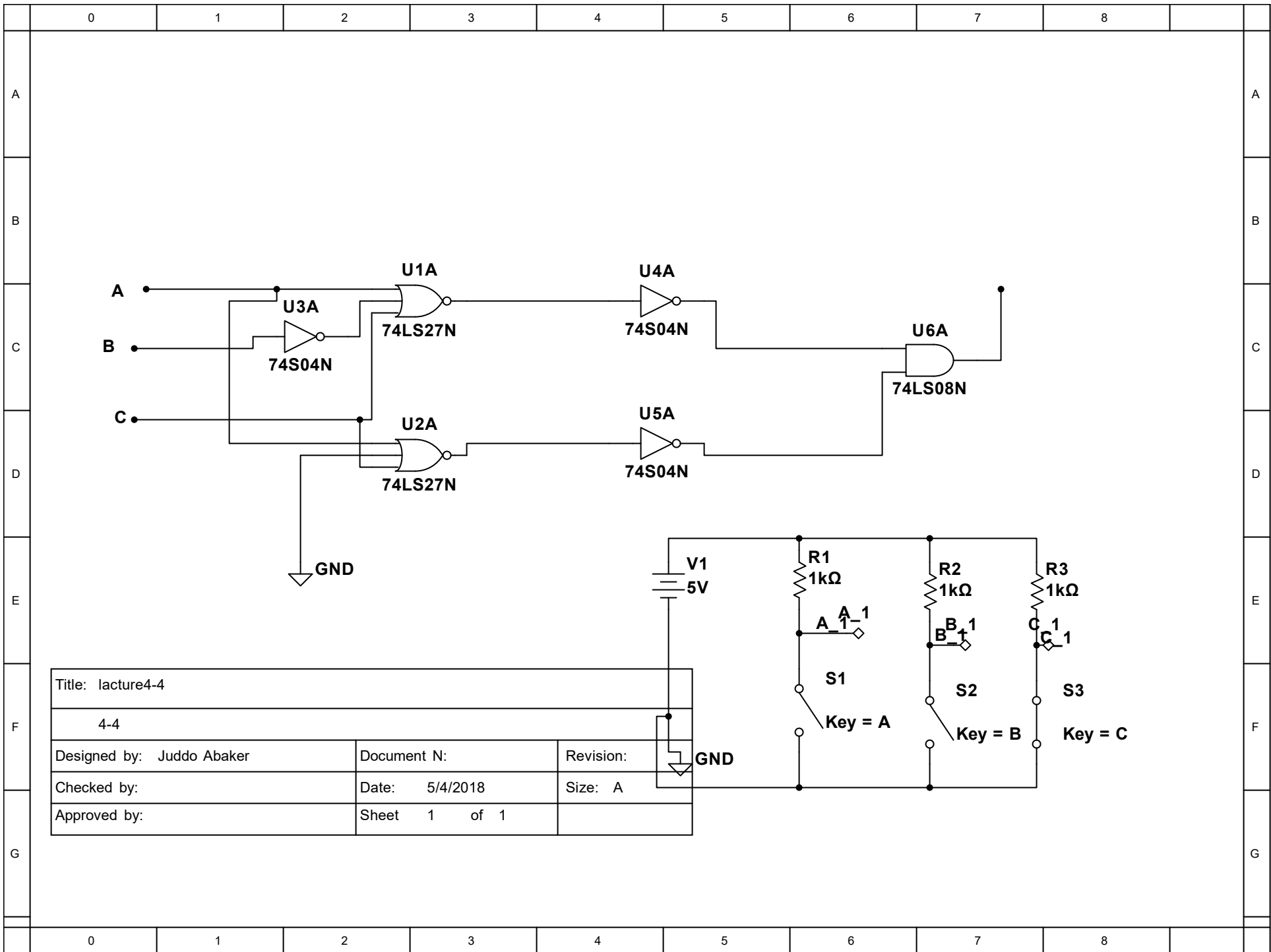

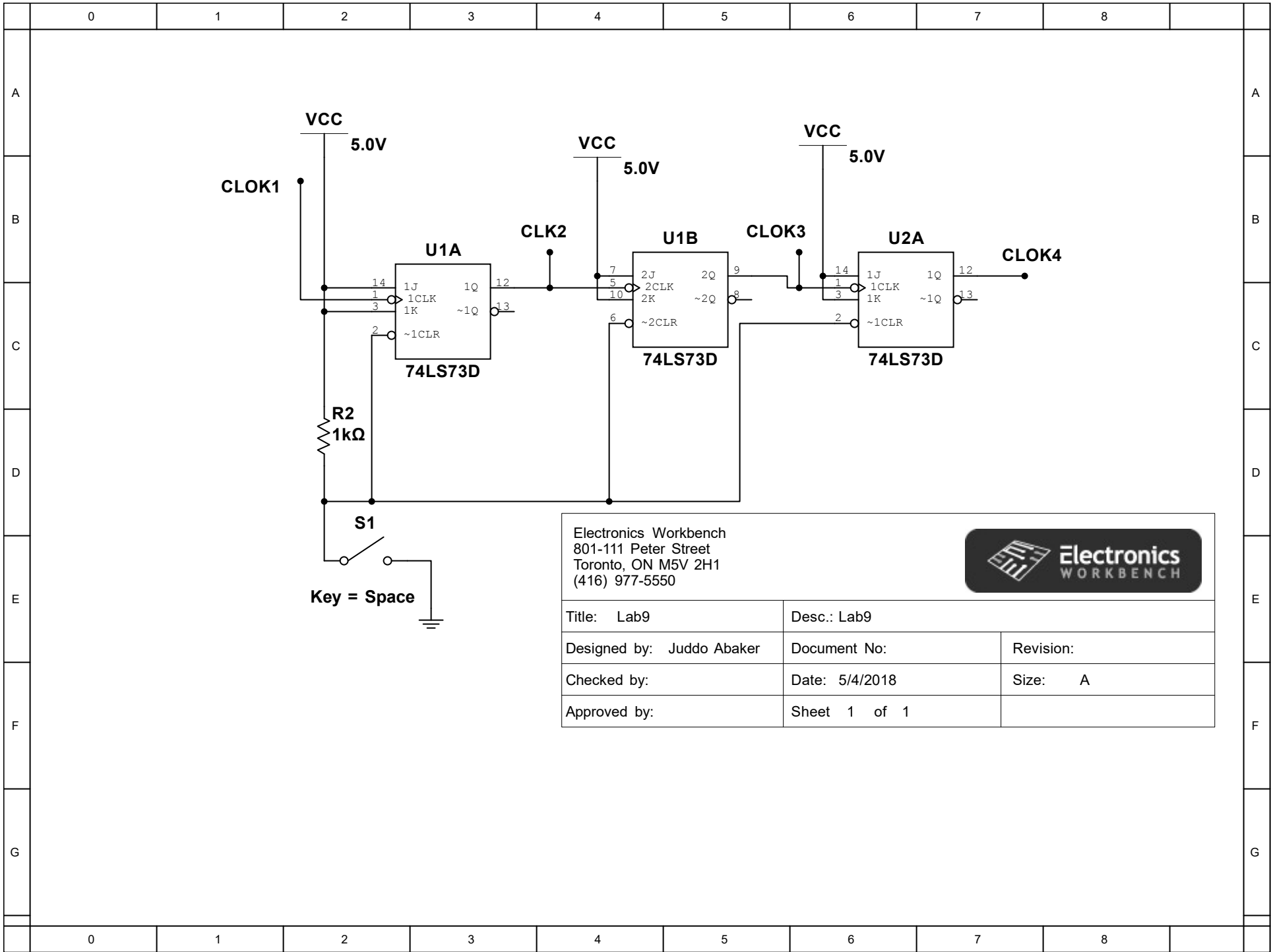

Electronics Workbench
 801-111 Peter Street
 Toronto, ON M5V 2H1
 (416) 977-5550



| | | | |
|---------------------------|----------------|-------------|--|
| Title: Lab9 | | Desc.: Lab9 | |
| Designed by: Juddo Abaker | Document No: | Revision: | |
| Checked by: | Date: 5/4/2018 | Size: A | |
| Approved by: | Sheet 1 of 1 | | |

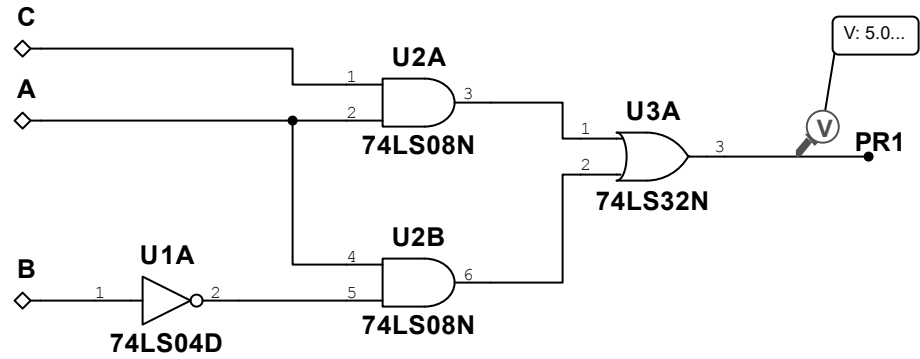
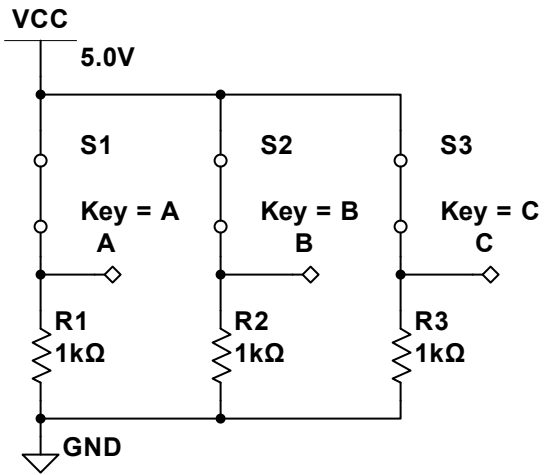

Sum of Products Circuit: $AB' \text{ or } AC$

| | | |
|--------------------------------|----------------|-----------|
| Title: Lab 8 - Sum of Products | | |
| Lab 8 - Sum of Products | | |
| Designed by: BAB, SPK, JiA | Document N: | Revision: |
| Checked by: | Date: 5/4/2018 | Size: A |
| Approved by: | Sheet 1 of 1 | |

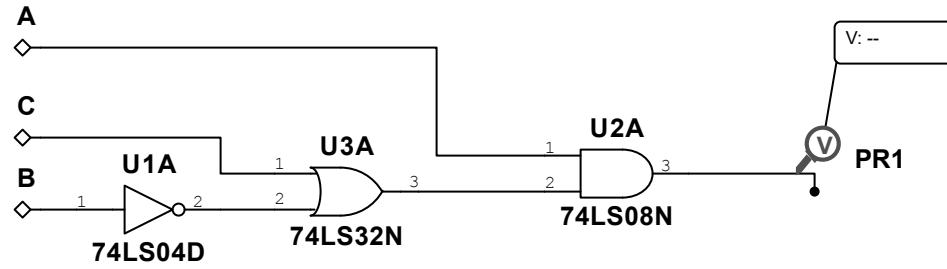
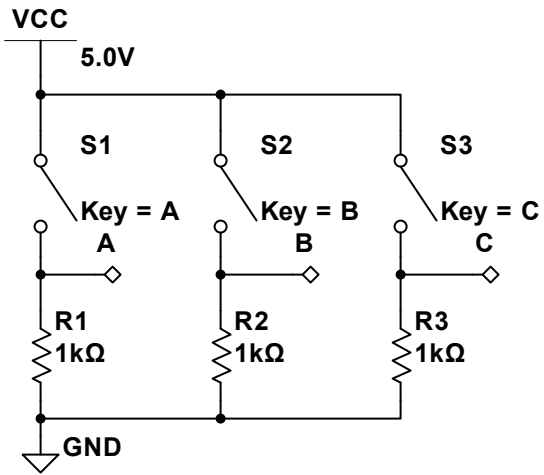

Product of Sums Circuit: $A * (B' + C)$

Title: Lab 8 - Product of Sums

Lab 8 - Product of Sums

Designed by: BAB, SPK, JiA

Document N:

Revision:

Checked by:

Date: 5/4/2018

Size: A

Approved by:

Sheet 1 of 1